

**El Dorado Hills Area  
Planning Advisory Committee**

**US 50/El Dorado Hills  
Blvd Interchange  
Improvements - Phase 2B**

March 12, 2025





# Agenda

- Purpose & Need
- Proposed Improvements
- Next Steps
- Schedule
- Q&A



## Project History

- Environmental Impact Report (EIR) final adoption in 2003
- Phase 1 completed in 2006
- Phase 2A completed in 2012
- Phase 2B.1 completed in 2015
- Phase 2B.2 anticipated completion in 2028 (Final Phase)



## Purpose & Need

- Remaining component of the phased interchange reconstruction at US 50 / Latrobe Road / El Dorado Hills Blvd
- Enhance the operational efficiency, safety, and capacity of the interchange
- Correct existing deficiencies, accommodate future traffic demands, and improve overall traffic flow & safety within the interchange
- Provide enhanced multi-modal facilities for bicyclists and pedestrians



## Proposed Improvements

- Reconstruction and widening of the eastbound loop off-ramp
- Reconstruction and widening of the eastbound diagonal on-ramp to two lanes and adding ramp metering
- Adding an additional lane to northbound El Dorado Hills Blvd
- Improving bicycle and pedestrian facilities
- Additional drainage, water quality treatment, retaining walls, and modifications to the Carson Creek culvert



# Eastbound Offramp & Onramp Improvements

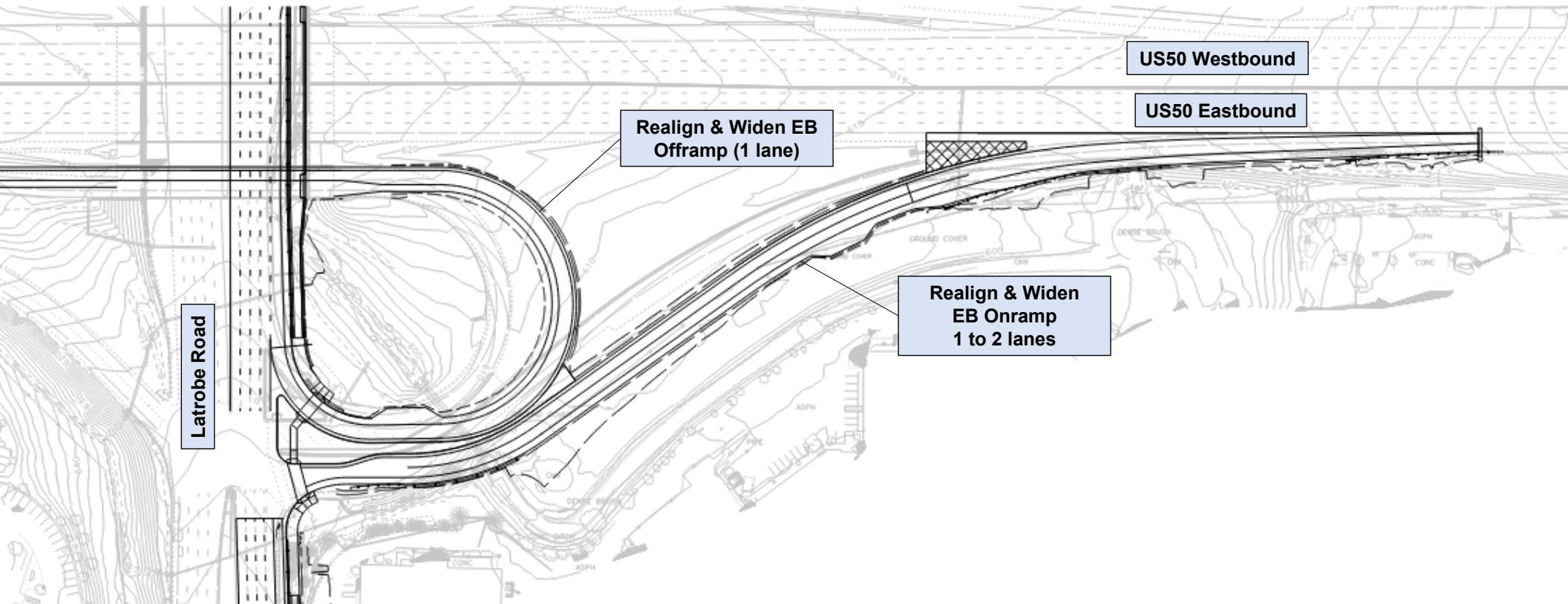



# Latrobe Rd & El Dorado Hills Blvd Improvements

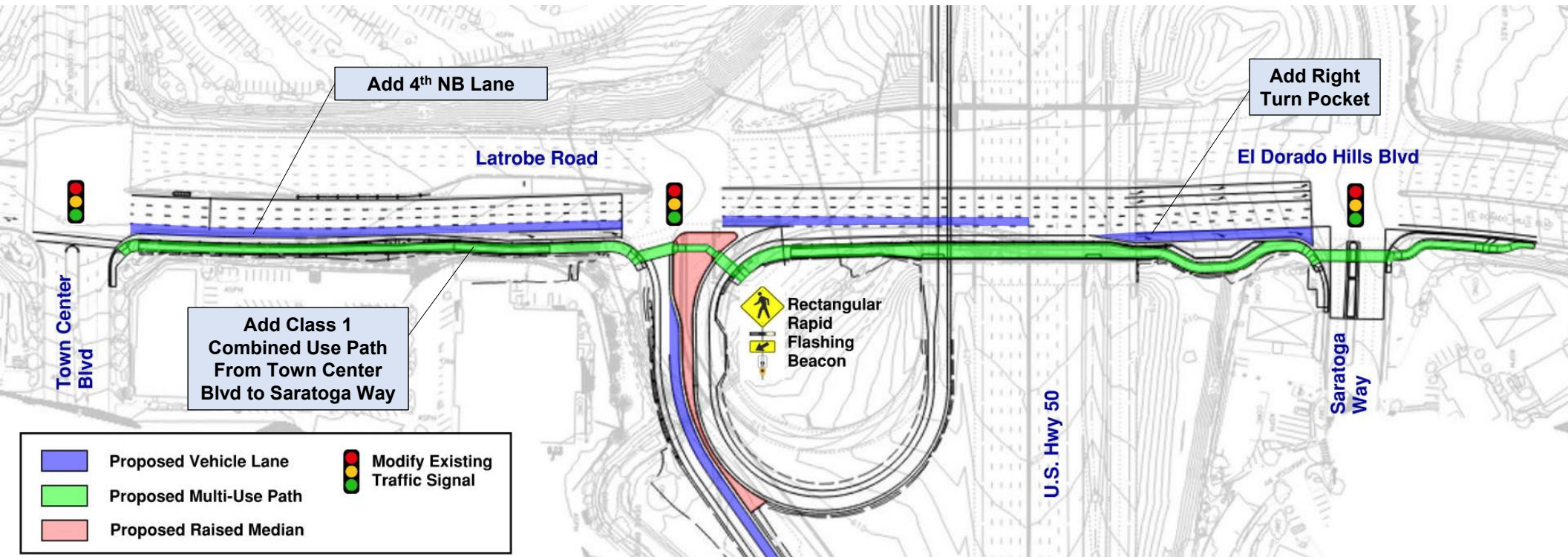



# Latrobe Rd & El Dorado Hills Blvd Improvements



**Type 85 Concrete Barrier**

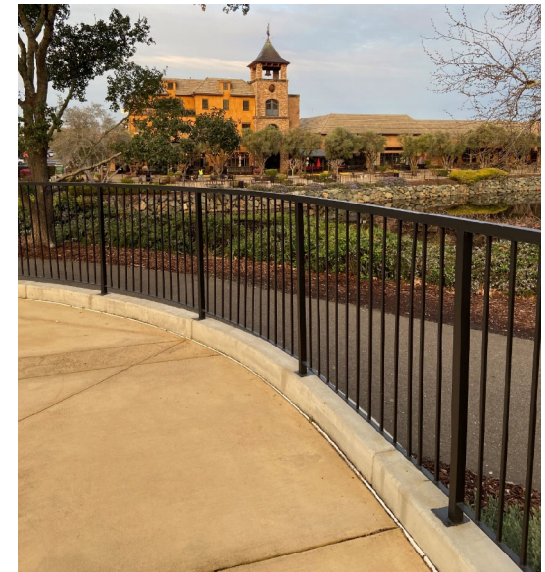
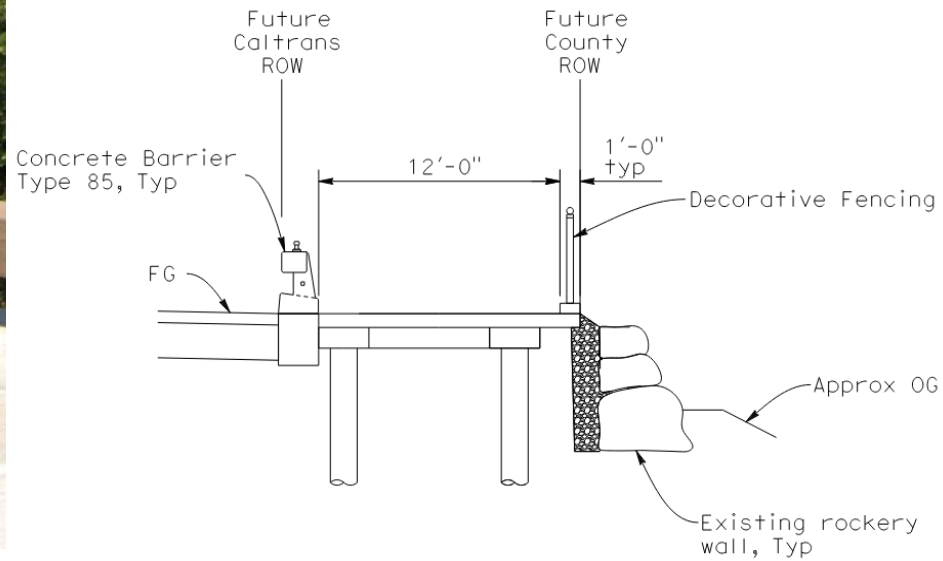

**Decorative Fencing**



## Next Steps

### Engineering Technical Studies

- Drainage & Stormwater Design
- Geotechnical Design
- Retaining Walls
- Traffic Management Plan
- Construction Staging

### Environmental Revalidation

- El Dorado County is CEQA Lead Agency
- Draft CEQA under review by County



# Schedule

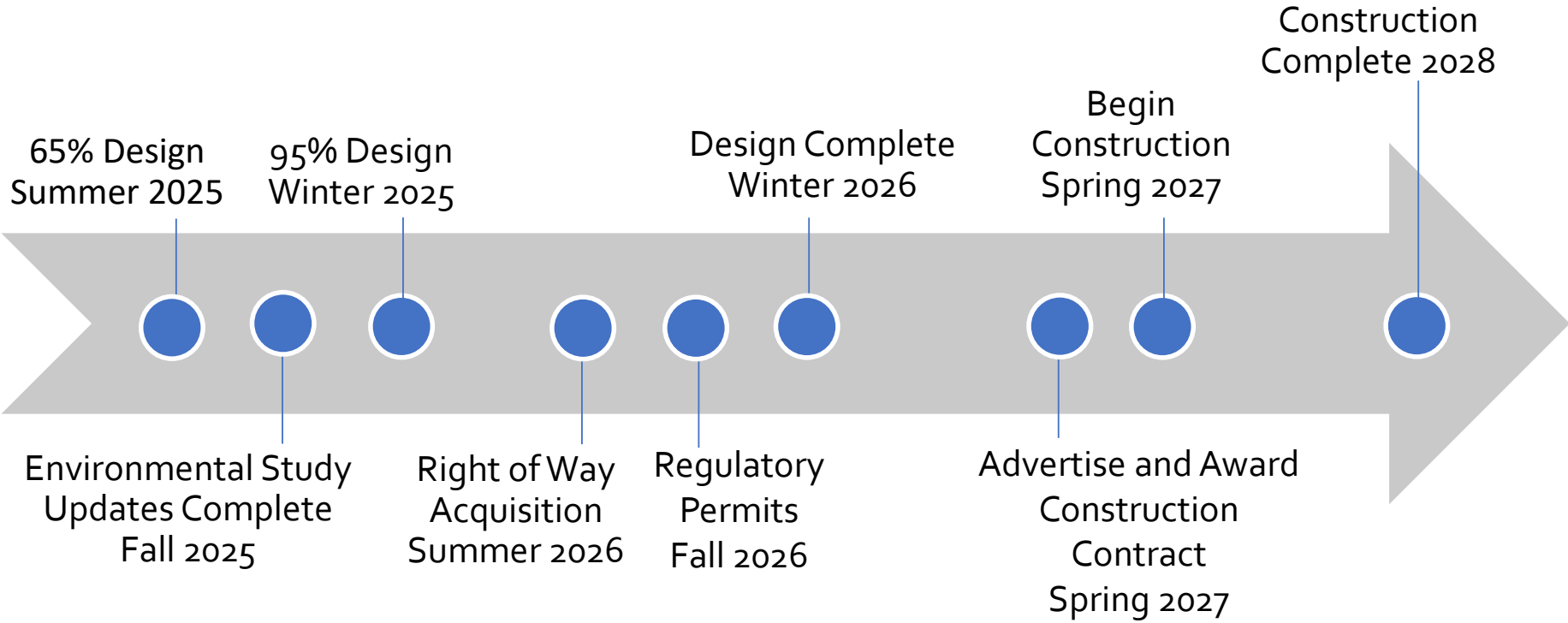



## Questions?

### Contact Information:

Dustin Harrington, Project Manager

El Dorado County

[dustin.harrington@edcgov.us](mailto:dustin.harrington@edcgov.us)

(530) 621-5950

**THANK YOU**